



The World's Leading Producer of Air Movement Products

Range Hood Exhaust

Range Hood Concerns...

SOLVED!

S&P, the world's leading producer of air movement products, offers a full selection of fan solutions for all of your range hood ventilation requirements. In-line remote fans are the most effective way to vent today's range hoods and does so with less noise, better air flow and is both affordable and aesthetically appealing (the fan is hidden). In addition, S&P offers more solutions with multiple fan choices to meet all your requirements. Whatever your requirements... **S&P has a solution.**



Inline Fans For Range Hood Exhaust

TD-MIXVENT SERIES

The TD series is the perfect range hood ventilator for most typical installations. These units handle a significant amount of pressure (associated with most jobs) and extremely good air movement, with a minimum of space required. Suitable for 10" through 12" round duct applications, from 541-1050 CFM (cubic feet of air per minute). Strong, quiet, easy to install (in even the tightest spaces) and years of trouble free operation.



PV-POWERVENT SERIES

The PV Series is the perfect solution for installations that require long or complicated duct runs. These sturdy units are available for 4" through 12" round duct installations: from 108-942 CFM. The centrifugal blade designs are able to overcome extreme resistance for even the most challenging installations. They include the same totally enclosed motors as the popular TD series to ensure long, trouble free life. The PV series is the right choice for more difficult installations.



Range Hood Advantages

Today the kitchen has become the heart of our homes, it's where we relax, gather and enjoy family and friends. S&P offers a range of inline fans to fit your range hood needs by offering many advantages over traditional (in hood) fans. By virtue of the remote mounting, the noise is kept further from the living space, further reducing the sound level of the fan. Remote mounting also allows for a duct silencer (SIL) to be mounted between the fan and the range hood, reducing the fan noise level by another 50% or more. S&P remote fans also offer extended duty times, low maintenance, and do not detract from the homes aesthetics, unlike some unsightly roof mounted units. S&P remote fans are the clear choice for the strongest quietest installation.

How to Size Your Kitchen Ventilation System

Due to varying capacities for moving air, prior to selecting your range hood fan, be sure to consult with local residential codes and the range manufacturer's recommendations. If you are unable to determine any manufacturer's recommendation, S&P has provided the following illustration to assist you with accurately calculating your fan size.

The following recommendations follow the Home Ventilating Institute (HVI) guidelines.



Wall Mount Installations:

100 CFM per foot of width.

Example:

48" (4 ft.) wide hood will require 400 CFM.

Feet of Width	4
CFM per Foot	x 100
Air Flow [CFM]	400

Island Mount Installations:

150 CFM per foot of width.

Example: 48" (4 ft.) wide hood will require 600 CFM.

Feet of Width	4
CFM per Foot	x 150
Air Flow [CFM]	600

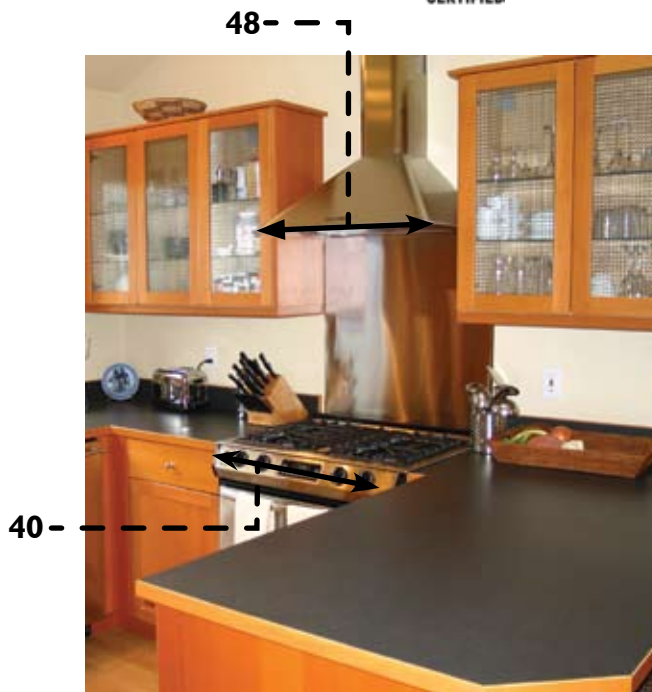

HVI's recommended kitchen range hood ventilation rates vary and depend on the type of cooking performed. The minimum rates are 40 CFM per lineal foot for a kitchen range hood placed along a wall and 50 CFM per lineal foot for island hoods. However, HVI recommends 100 CFM per lineal foot for wall-mounted kitchen range hoods and 150 CFM per lineal foot for island kitchen range hoods. Kitchen range hoods equipped with multiple speed settings allow low-level, quiet ventilation for light cooking with the ability for effective ventilation when needed. For "professional" style cook-tops, HVI recommends following the cooktop manufacturer's advice to estimate the approximate CFM requirements.

Typical TD Installation

TD-SERIES Fan

ACOP Mounting Clamps

Optional SIL-Silencer

More Air Flow • Less Noise • Easy to Install

Warranty

Five (5) year limited warranty.

Range

The TD-MIXVENT series consists of eight (8) nominal sized in-line fans. All models are specifically designed for direct connection in-line with industry standard diameter round ducting.

Construction

The TD-MIXVENT models 100, 100x, 125, 150, 200 and 200x are manufactured in tough reinforced plastic, models 250 and 315 have a metal casing and are finished in a tough epoxy-polyester paint coating. The TD fan duct connection flanges are manufactured from reinforced plastic, except for models 200, 200x, 250 and 315 which are constructed from epoxy-polyester coated metal.

Impellers

The impeller blades for models 100, 100x, 125 and 150 and 200x are molded in tough ABS plastic. Models 200, 250 and 315 are metal.

Motors

Models 100, 100x and 125 :

Single-phase, 120V 60Hz, shaded pole induction asynchronous motor in die cast aluminum. All motors include direct two speed connection and are also suitable for voltage speed control.

- Class II electrical insulation (model 100) & Class I (models 100x and 125)
- IP 44 Protection
- Class B Motor Insulation
- Safety auto reset Thermal Overload Protection (fuse type)
- Self-lubricating sleeve bearings.
- Suitable for working airstreams up to 104° F (40°C).

Models 150, 200, 200x, 250 and 315:

- Single-phase induction asynchronous motor, with permanent capacitor and external rotor constructed of die cast aluminum. All models include direct two speed connection and are also suitable for voltage speed control
- Class I electrical insulation
- IP 44 Protection
- Thermal Overload Protection
- Class B Motor Insulation
- Sealed For Life, ball bearings
- Suitable for working airstreams up to 140° F (60°C).

Dimensional Data

Dimensions (inches/mm)

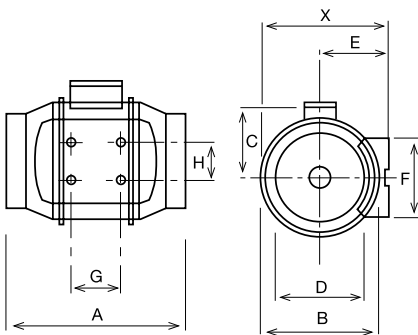

This is the complete TD-MIXVENT line that is offered. Please refer to page 7 for specific range hood applications.

TD - MIXVENT

Technical Specifications

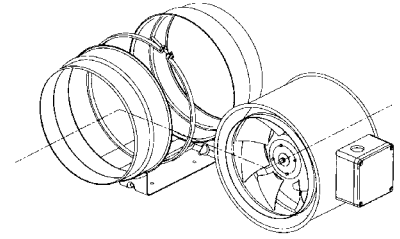

Soler & Palau USA certifies that the TD range shown herein is licensed to bear the AMCA Seal. The ratings shown are based on tests and procedures performed in accordance with AMCA Publication 211 and comply with the requirements of the AMCA Certified Ratings Program.



Sound

Fan sound levels are measured in sones. At this time there are no sone level test standards available through HVI due to the fact that remote mounted fan noise levels are in proportion to the following: type of duct, length of duct, fan distance from the intake source and other miscellaneous factors. However it is generally accepted that remote mounted venting is usually quieter than standard (in room) venting.

Model	X	A	B	C	D	E	F	G	H
TD-100	5 15/16 151	9 1/8 232	5 7/16 138	3 3/4 96	3 7/8 98	3 1/4 82	3 3/4 95	1 7/8 48	5 3/16 131
TD-100x	7 3/8 188	11 15/16 303	6 15/16 176	4 1/8 115	3 13/16 97	3 15/16 100	3 9/16 90	3 1/8 80	2 1/8 60
TD-125	7 3/8 188	16 7/16 258	6 15/16 176	5 115	4 13/16 123	3 15/16 100	3 9/16 90	3 1/8 80	2 3/8 60
TD-150	8 3/8 212	18 1/4 295	7 7/8 200	5 9/16 141	5 13/16 147	4 3/8 112	5 1/8 130	3 1/8 80	2 1/4 60
TD-200	9 1/8 233	19 11/16 302	8 9/16 217	5 9/16 141	7 13/16 198	4 7/8 124	5 1/2 140	3 15/16 100	3 11/16 94
TD-200x	9 1/8 233	19 11/16 302	8 9/16 217	5 9/16 141	7 13/16 198	4 7/8 124	5 1/2 140	3 15/16 100	3 11/16 94
TD-250	11 7/16 291	25 3/4 386	10 11/16 272	7 9/16 192	9 3/4 248	6 1/8 155	6 5/8 168	5 11/16 145	5 1/2 140
TD-315	14 356	17 3/4 450	13 1/4 336	8 13/16 224	12 1/4 312	7 3/8 188	8 1/4 210	7 3/16 182	7 178

Typical PV Installation

PV-SERIES Fan

Standard PV
Wiring Box



More Power • Longer Life • More Choices

All twelve PV model sizes (PV 100, 100x, 125, 125x, 150, 150x, 200, 200x, 250, 250x, 315 & 315x) include the following specifications:

PV-POWERVENT

Technical Specifications

Warranty

Five (5) year limited warranty.

Casing

- Manufactured from high grade pressed galvanized steel, with black baked enamel coating.
- Extra long inlet and discharge collars make installation quick and trouble free.
- Supplied with a strong galvanized steel mounting bracket.
- Supplied with a remote mounting, prewired wiring junction box.

Wheel / Impeller

- Backward curved centrifugal type constructed of metal.
- Factory matched to an external rotor motor and dynamically balanced to eliminate vibration.

Accessories

A wide range of accessories is available to complete the most demanding installation. See pages 8 & 10.

Motor

- Totally enclosed permanent split capacitor start and run external rotor motors.
- 115V 60Hz (single phase) electrical connection.
- Permanently sealed, self lubricating precision ball bearings.
- Safety Thermal Overload Protection Cut-Out (Automatic Reset Type).
- All Models are suitable for working airstreams up to 140° F

Code Approval

- All models have been independently safety tested by Underwriters Laboratories, Inc. and are UL and cUL Listed.
- Independently safety tested by Intertek Laboratories, and are ETL Listed.
- Independently tested for Airflow Performance. The PV range is licensed to bear the AMCA seal for Air Performance.
- The PV product range is certified by the Home Ventilating Institute (HVI) for Air Performance.
- Models PV-150x and greater are ENERGY STAR® qualified.

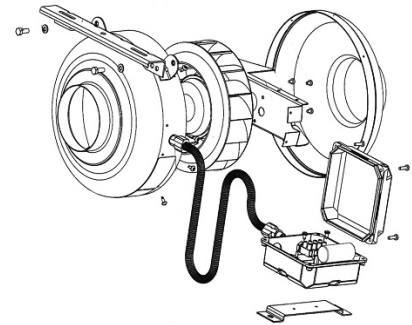

Soler & Palau USA certifies that the PV range shown herein is licensed to bear the AMCA Seal. The ratings shown are based on tests and procedures performed in accordance with AMCA Publication 211 and comply with the requirements of the AMCA Certified Ratings Program.



Dimensional Data

Dimensions (inches/mm)

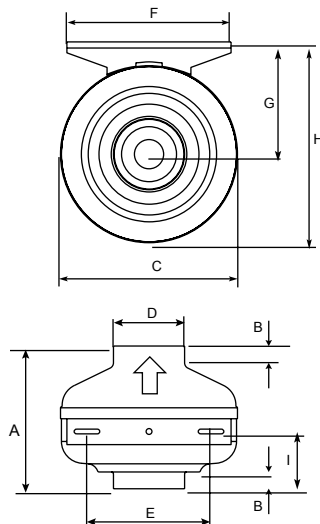

Model	A	B	C	D	E	F	G	H	I	Weight lbs(kgs)
PV-100	7 5/8 194	1 25	9 1/2 241	3 7/8 98	6 11/16 170	8 7/8 225	6 1/16 154	10 13/16 275	3 1/4 83	7 3.0
PV-100x	7 5/8 194	1 25	9 1/2 241	3 7/8 98	6 11/16 170	8 7/8 225	6 1/16 154	10 13/16 275	3 1/4 83	7 3.0
PV-125	7 5/8 194	1 25	9 1/2 241	4 7/8 124	6 11/16 170	8 7/8 225	6 1/16 154	10 13/16 275	3 7/16 87	7 3.0
PV-125x	7 5/8 194	1 25	9 1/2 241	4 7/8 124	6 11/16 170	8 7/8 225	6 1/16 154	10 13/16 275	3 7/16 87	7 3.0
PV-150	8 1/2 216	1 25	13 1/8 333	5 7/8 149	6 11/16 170	8 7/8 225	7 7/8 200	14 3/8 365	3 76	11 5.0
PV-150x	8 1/2 216	1 25	13 1/8 333	5 7/8 149	6 11/16 170	8 7/8 225	7 7/8 200	14 3/8 365	3 76	11 5.0
PV-200	8 1/2 216	1 25	13 1/8 333	7 7/8 200	6 11/16 170	8 7/8 225	7 7/8 200	14 3/8 365	3 11/16 94	11 5.0
PV-200x	8 1/2 216	1 25	13 1/8 333	7 7/8 200	6 11/16 170	8 7/8 225	7 7/8 200	14 3/8 365	3 11/16 94	11 5.0
PV-250	8 1/2 216	1 25	13 1/8 333	9 7/8 251	6 11/16 170	8 7/8 225	7 7/8 200	14 3/8 365	3 1/4 83	13 6.0
PV-250x	8 1/2 216	1 25	13 1/8 333	9 7/8 251	6 11/16 170	8 7/8 225	7 7/8 200	14 3/8 365	3 1/4 83	13 6.0
PV-315	9 1/16 230	1 25	15 13/16 401	12 5/16 312	6 11/16 170	8 7/8 225	9 3/16 234	17 1/8 435	3 1/2 89	21 10.0
PV-315x	9 1/16 230	1 25	15 13/16 401	12 5/16 312	6 11/16 170	8 7/8 225	9 3/16 234	17 1/8 435	3 1/2 89	21 10.0



*PV 150x and greater are currently ENERGY STAR® qualified

Sound

Fan sound levels are measured in sones. At this time there are no sone level test standards available through HVI due to the fact that remote mounted fan noise levels are in proportion to the following: type of duct, length of duct, fan distance from the intake source and other miscellaneous factors. However it is generally accepted that remote mounted venting is usually quieter than standard (in room) venting.

TD-MIXVENT SERIES

Technical Data



Air Performance

Model	Nom. RPM	Volts	Max. Watts	Speed	CFM v Static Pressure (SP) Ins. WG								Max. SP	Duct Dia. Ins.
					0"	0.125"	0.25"	0.375"	0.5"	0.75"	1.0"	1.25"		
TD 250	1870	120	168	LS	543	488	440	389	333	250	208	164	1.85	10"
	2601	120	255	HS	765	729	689	655	621	500	344	275	2.35	10"
TD 315	1875	120	226	LS	793	678	579	464	345	224	167	127	1.5	12.4"
	2563	120	347	HS	1089	1014	939	865	780	616	460	341	2.5	12.4"

Performance certified is for installation type D-Ducted inlet, Ducted outlet. Performance ratings do not include the effects of appurtenances (accessories). Speed (RPM or RPS) shown is nominal. Performance is based on actual speed of test.

LS= LowSpeed
HS=High Speed



Soler & Palau USA certifies that the TD range shown herein is licensed to bear the AMCA Seal. The ratings shown are based on tests and procedures performed in accordance with AMCA Publication 211 and comply with the requirements of the AMCA Certified Ratings Program.



PV-POWERVENT SERIES

Technical Data



Air Performance

Trade Name	Model No.	Nom. RPM	Volts	Max. Watts	CFM v Static Pressure (SP) Ins. WG										Max. SP	Duct Dia. Ins.
					0"	0.125"	0.25"	0.375"	0.5"	0.75"	1.0"	1.25"	1.5"			
Power Vent-100	PV-100	1400	115	57	108	100	92	85	78	66	52	33	18	1.7	4"	
Power Vent-100x	PV-100x	2880	115	84	153	142	130	120	111	96	80	63	34	1.85	4"	
Power Vent-125	PV-125	2350	115	58	128	104	85	74	63	47	32	15	-	1.43	5"	
Power Vent-125x	PV-125x	2745	115	85	206	190	170	153	135	110	88	62	33	1.77	5"	
Power Vent-150	PV-150	2750	115	78	245	205	177	157	129	93	59	-	-	1.2	6"	
Power Vent-150x	PV-150x	3075	115	149	438	420	395	368	335	285	240	203	161	2.29	6"	
Power Vent-200	PV-200	3100	115	130	402	375	350	327	296	239	179	135	85	1.94	8"	
Power Vent-200x	PV-200x	2930	115	180	544	515	485	446	415	360	312	273	230	2.64	8"	
Power Vent-250	PV-250	3000	115	200	587	555	525	495	472	412	355	312	270	2.61	10"	
Power Vent-250x	PV-250x	3045	115	214	618	595	570	540	510	450	390	340	297	2.8	10"	
Power Vent-315	PV-315	2600	115	170	654	605	570	525	487	408	333	265	203	2.21	12.4"	
Power Vent-315x	PV-315x	2650	115	370	942	905	859	811	762	622	508	440	390	3.9	12.4"	

Performance certified is for installation type D-Ducted inlet, Ducted outlet. Performance ratings do not include the effects of appurtenances (accessories). Speed (RPM or RPS) shown is nominal. Performance is based on actual speed of test.



Soler & Palau USA certifies that the PV range shown herein is licensed to bear the AMCA Seal. The ratings shown are based on tests and procedures performed in accordance with AMCA Publication 211 and comply with the requirements of the AMCA Certified Ratings Program.



*PV 150x and larger are currently ENERGY STAR® certified



All products manufactured by S&P have undergone extensive tests and quality assurance programs to ensure that the products supplied meet the latest international performance and safety standards. Soler & Palau is an ISO9001 registered company, and has onsite ENAC and AMCA third party accredited test laboratory facilities.

Range Hood Accessories

SIL-Sound Attenuator

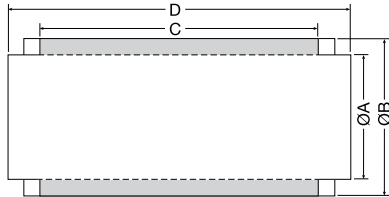

The galvanized steel silencer is used for kitchen range hood ventilation and other applications where noise is a concern. The S&P silencer reduces the “actual” sound level of the kitchen ventilation system by 50% or more. They feature rubber seals on inlet and outlet.

Dimension in inches/mm

Model	A	B	C	D	Weight (lbs)
SIL-125	5 125	9 13/16 250	27 9/16 700	35 7/16 900	15
SIL-150	6 5/16 160	9 13/16 250	27 9/16 700	35 7/16 900	18
SIL-200	7 7/8 200	12 3/8 315	27 9/16 700	35 7/16 900	21
SIL-250	9 13/16 250	14 355	27 9/16 700	35 7/16 900	32
SIL-315	12 3/8 315	15 3/4 400	27 9/16 700	33 14/16 860	32
SIL-355	14 355	17 11/16 450	27 9/16 700	33 14/16 860	40
SIL-400	15 3/4 400	19 11/16 500	27 9/16 700	33 14/16 860	40

CAR-Backdraft Damper

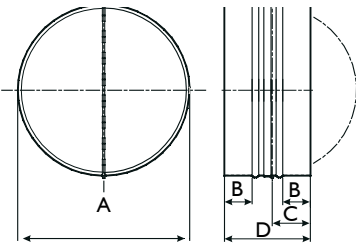

Backdraft dampers are designed with galvanized steel collars and have lightweight aluminum damper blades. They are spring loaded for positive closure.

Dimension in inches/mm

Model	A	B	C	Weight (lbs)
CAR-100	100 3 15/16	80 3 2/16	32 1 4/16	1
CAR-125	125 4 15/16	100 3 15/16	42 1 10/16	1
CAR-150	150 5 14/16	120 4 12/16	52 2 1/16	1
CAR-200	160 6 5/16	120 4 12/16	52 2 1/16	1
CAR-250	200 7 14/16	140 5 8/16	62 2 7/16	1
CAR-315	250 9 13/16	140 5 8/16	62 2 7/16	2
CAR-355	315 12 6/16	140 5 8/16	62 2 7/16	2

Range Hood Accessories continued

ACOP-Vent Mounting Clamp

Manufactured from galvanized steel with an insulated rubber duct seal. These clamps facilitate the connection and disconnection of round ventilation ducts. All models incorporate internal hanging tabs for suspending the ducting / fan when horizontally mounted.

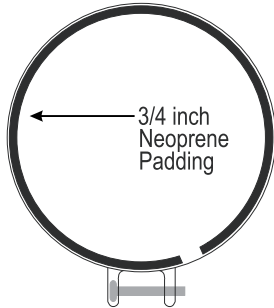

Model	Description	Weight (lbs)
ACOP-V100	4" Connector clamps (2 ea., sold in pairs)	1
ACOP-V125	5" Connector clamps (2 ea., sold in pairs)	1
ACOP-V150	6" Connector clamps (2 ea., sold in pairs)	1
ACOP-V200	8" Connector clamps (2 ea., sold in pairs)	1
ACOP-V250	10" Connector clamps (2 ea., sold in pairs)	1
ACOP-V315	12.4" Connector clamps (2 ea., sold in pairs)	1

RC-Roof Cap

Galvanized steel roof caps with damper flap closure and bird screen. Duct sizes from 4" to 10".



Dimension in inches/mm

Model	A	B	C	D	E	F	G	Weight (lbs)
RC-4	6 / 150	6 / 150	3 1/2 / 90	12 / 300	12 / 300	4 1/2 / 115	2 1/2 / 60	1
RC-6	8 / 200	8 / 200	4 / 100	14 / 355	14 / 355	5 / 125	4 / 100	1
RC-8	8 / 200	8 / 200	4 / 100	14 / 355	14 / 355	5 / 125	4 / 100	1
RC-10	11 / 280	11 / 280	5 / 125	17 / 430	17 / 430	7 / 175	4 / 100	1

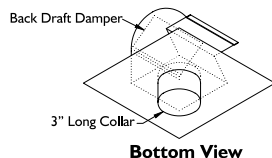
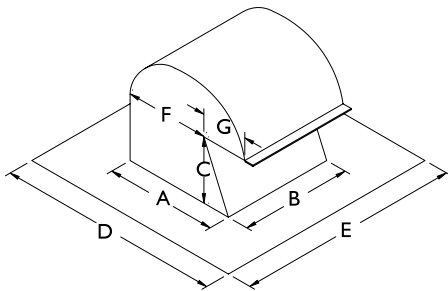



Soler & Palau USA
6393 Powers Ave.
Jacksonville, FL 32217
800.961.7370
800.961.7379
www.solerpalau-usa.com

Soler & Palau Canada
61 A Baywood road
Toronto, ON M9V 3Y8
866.733.0233
866.385.5346
www.solerpalaucanada.com